



WITZENBERG

Municipality • Munisipaliteit • UMasipala Wase

Reference/Verwysing/iRef: 08/2/9/10
Enquiries/Navrae/Imibuzo: M Frieslaar

04 August 2011

TO WHOM IT MAY CONCERN

Dear Sir / Madam

REQUEST FOR FORMAL WRITTEN PRICE QUOTATIONS:

(Over R30 000.00 up to a transaction value of R200 000.00 VAT included)

Kindly furnish us with a written quotation for the supply of the following:

SUPPLY AND DELIVERY OF 12X6M³ SKIP BINS

The quotation, placed in a sealed envelope clearly marked "**08/2/9/10: SUPPLY AND DELIVERY OF 12 X 6M³ SKIP BINS**" must be put in the bid box located at the entrance of the Witzenberg Municipal Offices, 50 Voortrekker Street, Ceres no later than **FRIDAY, 12 August 2011 at 12:00**. The bid box is generally open 24 hours a day, 7 days a week. Telephonic, facsimile, electronic / e-mailed and late bids will not be accepted. Bids may only be submitted on the bid documentation that has been issued.

The following conditions will apply

- Price(s) quoted must be valid for at least sixty (60) days from date of your offer.
- Price(s) quoted must be firm and must be inclusive of VAT.
- A firm delivery period must be indicated.
- This quotation will be evaluated in terms of the 80/20 preference point system as prescribed in the Preferential Procurement Policy Framework Act (No 5 of 2000) and for this purpose the enclosed forms MBD 2, MBD 4, MBD 6.1 & MBD 6.9 must be scrutinized, completed and submitted together with your quotation.
- The successful provider will be the one scoring the highest points.
- This bid document and all its contents are subject to the General Conditions of Contract July 2010 as amended. These conditions are available on request.
- Payments to the successful bidder in terms of this contract will be processed within 30 days after receipt of a valid tax invoice for goods and/or services rendered to the satisfaction of the municipality.
- The checklist at the back of the bid document must be completed and adhered to.

NB: No quotations will be considered from persons in the service of the state

Failure to comply with these conditions may invalidate your offer.

Yours faithfully

**D NASSON
MUNICIPAL MANAGER**

REQUEST FOR A FORMAL WRITTEN PRICE QUOTATION

YOU ARE HEREBY INVITED TO BID FOR REQUIREMENTS OF THE WITZENBERG MUNICIPALITY

BID NUMBER: 08/2/9/10

CLOSING DATE: 12 August 2011

CLOSING TIME: 12:00

DESCRIPTION: SUPPLY AND DELIVERY OF 12 X 6M³ SKIP BINS

The following conditions to bid exist:

(Failure to comply may result in your bid being disqualified)

1. Bidders should ensure that bids are delivered timeously to the correct address as indicated below. If the bid is late, it will not be accepted for consideration. The bid box is generally open 24 hours a day, 7 days a week.
2. All quotation prices must **include VAT**.
3. Bids will be evaluated according to the 80/20 points system.
4. Documents can be obtained during office hours from Monday to Thursday: 8h00-13h00 and 13h45-17h00 and Friday: 8h00-13h00 and 14h00-16h00 from Witzenberg Municipality, Supply Chain Unit, Drommedaris Street, CERES at a cost of R30.00 per set.
5. The bid document is also available on the Municipality's website at www.witzenberg.gov.za
6. The quotation will be opened in the Council Chamber, Municipal offices, 50 Voortrekker Street, Ceres in public immediately after the closing time at 12:00.
7. **Telephonic, facsimile, electronic/mailed and late bids will not be accepted.**
8. The lowest or any quotation shall not necessarily be accepted and the Council reserves the right to accept any part of the bid.
9. **An original tax clearance certificate must be attached (MBD2). Bidders who are registered on the municipality's accredited supplier database and attached an original valid tax clearance certificate to their application form does not need to submit an original tax clearance certificate with their bid document. However, the onus is on the bidder to confirm with the Supply Chain Unit whether or not his/ her tax clearance certificate that was submitted with the supplier application form will be valid at the time of bid closing.**
10. All the information as requested on the preferential claim form must be completed in order to claim preferential points. A bidder whose claim form is not completed will not be eligible for any preferential points.
11. Do not dismember this Bid Document (do not take it apart or put documents between its pages).
12. The PROPOSAL and all other documents of the submission must be **attached behind** this Bid Document.
13. The bidder must complete the checklist at the back of this bid document

**SUBMIT BID DOCUMENTS
TO/ OR**

| | |
|--|--|
| <p>POSTAL ADDRESS: Municipal Manager PO Box 44 Ceres, 6835 (Ensure bid number and title are on envelope)</p> | <p>TO BE DEPOSITED IN: The bid box at the entrance of the Municipal Offices of Witzenberg 50 VOORTREKKER STREET CERES</p> |
| <p>CONTACT DETAILS FOR:</p> | |
| <p>Mr M Frieslaar Tel: (023) 312-1761 / 5 Email: mfrieslaar@witzenberg.gov.za</p> | |

**D NASSON
MUNICIPAL MANAGER**

WITZENBERG MUNICIPALITY
TERMS OF REFERENCE (TOR)

1. SCOPE

Purpose

Bids are hereby invited for the **Supply and Delivery of 12 x 6m³ Skip Bins.**

Background and description of project

Witzenberg Municipality includes the towns and rural areas of:

- Ceres,
- Prince Alfred's Hamlet,
- Op-die-Berg,
- Tulbagh, and
- Wolseley

Witzenberg Municipality is required to deliver services to the abovementioned areas.

2. EVALUATION CRITERIA

This bid will be evaluated according to the criteria and weight given in the table below:

| Evaluation Criteria | | Weighting |
|----------------------------|---|------------------|
| 2.1 Preference | HDI Ownership | 8 |
| | Women Ownership | 1 |
| | Disability | 1 |
| | 2.1.1 Enterprise within Western Cape Province | 10 |
| 2.2 Price | | 80 |
| Total | | 100 |

2.3 The preference points will be calculated as indicated in the following forms:

| | |
|---|---------|
| HDI | MBD 6.1 |
| Enterprise within Western Cape Province | MBD 6.9 |

Please do not alter any of the bid documents. It must be completed by hand.

WITZENBERG MUNICIPALITY
TECHNICAL SPECIFICATIONS

SPECS

BID NO 08/2/9/10: SUPPLY AND DELIVERY OF 12 X 6M³ SKIP BINS.

| DESCRIPTION | | COMPLY | | |
|-------------|--|--------|----|---|
| | | Yes | No | Details of deviations. If not sufficient space, attach annexure of deviations |
| 1. | All steelwork to be in accordance with SABS 0162 (Latest edition) Grade 300W | | | |
| 2. | Material 4,5mm hot – rolled mild steel plate | | | |
| 3. | Fully mig - welded | | | |
| 4. | Colour of all skips must be dark green | | | |

Bidder must complete checklist and certify that the checklist and attach specifications are the same.

The Bidder hereby confirms that the information given above is true and correct:

.....
(Name in Print)

.....
(Signature)

.....
(Capacity)

.....
(Date)

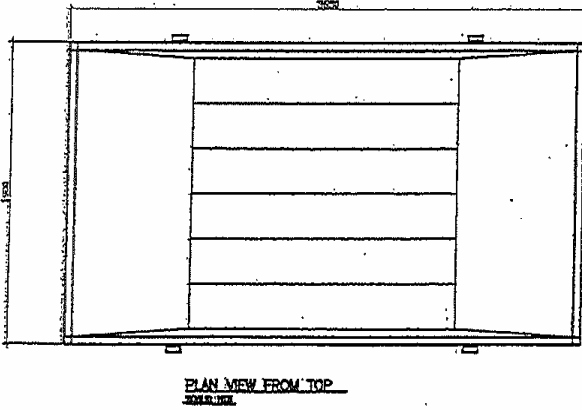
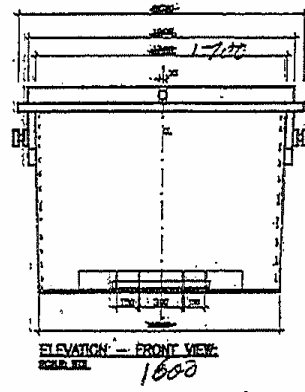
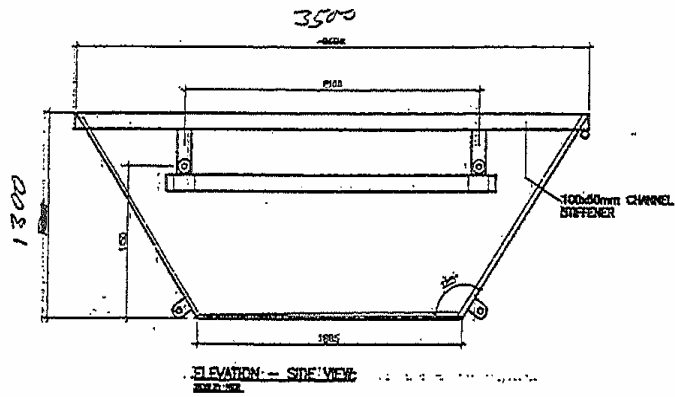

± 850 kg

3. DETAILS OF BIDDER

| | |
|--|--|
| Name of firm / entity / enterprise | |
| Trading as (if different from above) | |
| Postal address | |
| Physical address | |
| Contact Details of the Person Signing the Bid: | Name: _____ Telephone: _____ Fax: _____ Cellular Telephone: _____ e-mail address: _____ |
| Contact Details of the Senior Manager Responsible for Overseeing Contract Performance: | Name: _____ Telephone: _____ Fax: _____ Cellular Telephone: _____ e-mail address: _____ |
| Contact Details of the Bidder's proposed Project Manager who will represent the Bidder in the implementation processes: | Name: _____ Telephone: _____ Fax: _____ Cellular Telephone: _____ E-mail address: _____ |
| Company Income Tax no. | |
| VAT registration no. | |
| Company registration no. | |
| Any other Registration applicable to this Industry | |
| Bidder's banking details | Name of account holder: _____ Name of Bank: _____ Bank Account Number: _____ Branch Code: _____ |

TAX CLEARANCE REQUIREMENTS

IT IS A CONDITION OF BIDDING THAT -

1. The taxes of the successful bidder must be in order, or that satisfactory arrangements have been made with the Receiver of Revenue to meet his / her tax obligations.
2. The attached form "Application for Tax Clearance Certificate (in respect of bidders)" must be completed in all respects and submitted to the Receiver of Revenue where the bidder is registered for tax purposes. The Receiver of Revenue will then furnish the bidder with a Tax Clearance Certificate that will be valid for a period of twelve (12) months from date of issue. This Tax Clearance Certificate must be submitted in the original together with the bid. Failure to submit the original and valid Tax Clearance Certificate may invalidate the bid.
3. In bids where Consortia / Joint Ventures / Sub-contractors are involved each party must submit a separate Tax Clearance Certificate. Copies of the Application for Tax Clearance Certificates are available at any Receiver's Office.

Bidders who are registered on the municipality's accredited supplier database and attached an original valid tax clearance certificate to their application form does not need to submit an original tax clearance certificate with their bid document. However, the onus is on the bidder to confirm with the Supply Chain Unit whether or not his/ her tax clearance certificate that was submitted with the supplier application form will be valid at the time of bid closing.

MBD2/ Application for tax Certificate...

**PRICING SCHEDULE – FIRM PRICES
(PURCHASES)**

NOTE: ONLY FIRM PRICES WILL BE ACCEPTED. NON-FIRM PRICES (INCLUDING PRICES SUBJECT TO RATES OF EXCHANGE VARIATIONS) WILL NOT BE CONSIDERED

| | |
|-----------------------|------------------------------|
| Name of Bidder: | Bid Number: 08/2/9/10 |
| Closing Time: 12:00 | Closing Date: 12 August 2011 |

OFFER TO BE VALID FOR 60 DAYS FROM THE CLOSING DATE OF BID.

| ITEM NO | QUANTITY | DESCRIPTION | UNIT PRICE (incl. VAT) | TOTAL BID PRICE (incl. VAT) |
|---------|----------|-----------------------------------|---------------------------|--------------------------------|
| | | | R | R |
| 1 | 12 | Supply and Delivery of Skip Bins. | | |

Required by: Mr J Jacobs

At: Municipal Stores, Dromedaris Street, Ceres, 6835

Brand and model:

Country of Origin:

Does offer comply with specification? *YES/NO

If not to specification, indicate deviation(s)

Period required for delivery:

Delivery: *Firm/not firm

Note: All delivery costs must be included in the bid price and delivered to the prescribed destination.

DECLARATION OF INTEREST

- 1. No bid will be accepted from persons in the service of the state*.
- 2. Any person, having a kinship with persons in the service of the state, including a blood relationship, may make an offer or offers in terms of this invitation to bid. In view of possible allegations of favouritism, should the resulting bid, or part thereof, be awarded to persons connected with or related to persons in service of the state, it is required that the bidder or their authorised representative declare their position in relation to the evaluating/adjudicating authority and/or take an oath declaring his/her interest.
- 3 In order to give effect to the above, the following questionnaire must be completed and submitted with the bid.

3.1 Full Name:

3.2 Identity Number:

3.3 Company Registration Number:

3.4 Tax Reference Number:

3.5 VAT Registration Number:

3.6 Are you presently in the service of the state* **YES / NO**

3.6.1 If so, furnish particulars.
.....
.....

3.7 Have you been in the service of the state for the past twelve months? **YES / NO**

3.7.1 If so, furnish particulars.
.....
.....

3.8 Do you, have any relationship (family, friend, other) with persons in the service of the state and who may be involved with the evaluation and or adjudication of this bid? **YES/NO**

3.8.1 If so, furnish particulars.
.....
.....

3.9 Are you, aware of any relationship (family, friend, other) between a bidder and any persons in the service of the state who may be involved with the evaluation and or adjudication of this bid? **YES/NO**

3.9.1 If so, furnish particulars.
.....

.....
3.10. Are any of the company's directors, managers, shareholders or stakeholders in service of the state? **YES/NO**

3.10.1 If so, furnish particulars.

.....
.....

3.11 Are any spouse, child or parent of the company's directors managers, principle shareholders or stakeholders in service of the state? **YES/NO**

3.11.1 If so, furnish particulars.

.....
.....

CERTIFICATION

I, THE UNDERSIGNED (NAME) CERTIFY THAT THE INFORMATION FURNISHED ON THIS DECLARATION FORM IS CORRECT.I ACCEPT THAT THE STATE MAY ACT AGAINST ME SHOULD THIS DECLARATION PROVE TO BE FALSE.

.....
Signature

.....
Date

.....
Position

.....
Name of Bidder

* MSCM Regulations: "in the service of the state" means to be –

- (a) a member of –
 - (i) any municipal council;
 - (ii) any provincial legislature; or
 - (iii) the national Assembly or the national Council of provinces;
- (b) a member of the board of directors of any municipal entity;
- (c) an official of any municipality or municipal entity;
- (d) an employee of any national or provincial department, national or provincial public entity or constitutional institution within the meaning of the Public Finance Management Act, 1999 (Act No.1 of 1999);
- (e) a member of the accounting authority of any national or provincial public entity; or
- (f) an employee of Parliament or a provincial legislature.

RESPONSIVENESS AND EVALUATION CRITERIA

NB: Witzenberg Municipality may verify any information submitted in terms of this proposal and any information that is incorrect may result in that Bid being automatically disqualified and not considered further.

RESPONSIVENESS CRITERIA

No bid will be considered by Witzenberg Municipality unless it meets the following responsiveness criteria (for the bid to be considered responsive, the bid **must** meet the following requirements):

- a) The bid must be properly received in a sealed envelope clearly indicating the description of the service and the bid number for which the bid is submitted.
- b) The bid must be deposited in the relevant Bid box as indicated on the notice of the bid on or before the closing date and time of the bid. **Telephonic, facsimile, electronic/mailed and late bids will not be accepted.**
- c) An original Valid Tax Clearance Certificate must be attached to the bid document. **Bidders who are registered on the municipality's accredited supplier database and attached an original valid tax clearance certificate to their application form does not need to submit a tax clearance certificate with their bid document. However, the onus is on the bidder to confirm with the Supply Chain Unit whether or not his/ her tax clearance certificate that was submitted with the supplier application form will be valid at the time of bid closing.**
- d) The official bid document must be fully completed in indelible ink. Where information requested does not apply to the bidder and the space is left blank, it will be deemed to be not applicable.
- e) All requested relevant and/or additional documentation such as Compliance Certificates, professional registration, artisan qualification, etc, must be submitted with the bid document.
- f) Bidders must submit a certified statement signed by the bidder declaring that the bidder has no undisputed commitments for municipal services towards a municipality or other service provider in respect of which payment is overdue for more than 30 days (Annexure A).
- g) The bidder must be in good standing to do business with the public sector in terms of Regulation 38 of the Supply Chain Management Regulations (Government Gazette 27636 of 30 May 2005).
- h) If the entity submitting a bid is a Joint Venture or Consortium or Partnership, each party to that formation must submit all the above information.
- i) The bidder must adhere to the Pricing Instructions. **Bidders are required to bid for all items in the pricing schedule. If not the bid will be considered to be non-responsive**
- j) The Bidder's details must be provided.
- k) The necessary document authorising the Representative to sign and submit the bid on the bidder's behalf must be completed and signed.
- l) The Declaration of Interests by the bidder must be completed and signed.
- m) The bid must comply with all the minimum technical specifications.
- n) The MBD 9 (prohibition of restrictive practices) must be completed and signed.
- o) Checklist at the back of the bid document must be completed and adhered to.

EVALUATION OF BIDS

- All bids received shall be evaluated in terms of the Supply Chain Management Regulations and the Preferential Procurement Policy Framework Act.
- The Council reserves the right to accept all, some, or none of the bids submitted — either wholly or in part — and it is not obligated to accept the lowest bid.

AREAS TO BE INCLUDED IN EVALUATION PROCESS:

Evaluation of Preference Points

The point's allocation for this bid will be as follows:

| | |
|--------------|-------------------|
| Price | 80 points |
| Preference | <u>20 points</u> |
| Total | <u>100 points</u> |

PREFERENCE POINTS CLAIM FORM IN TERMS OF THE PREFERENTIAL PROCUREMENT REGULATIONS 2001

PURCHASES

This preference form must form part of all bids invited. It contains general information and serves as a claim form for Historically Disadvantaged Individual (HDI) preference points as well as a summary for preference points claimed for attainment of other specified goals.

NB: BEFORE COMPLETING THIS FORM, BIDDERS MUST STUDY THE GENERAL CONDITIONS, DEFINITIONS AND DIRECTIVES APPLICABLE IN RESPECT OF EQUITY OWNERSHIP BY HISTORICALLY DISADVANTAGED INDIVIDUALS (HDIs), AS PRESCRIBED IN THE PREFERENTIAL PROCUREMENT REGULATIONS, 2001.

1. GENERAL CONDITIONS

1.1 The following preference point systems are applicable to all bids:

- the 80/20 system for requirements with a Rand value of up to R500 000; and
- the 90/10 system for requirements with a Rand value above R500 000.

1.2 The value of this bid is estimated to not exceed R500 000 and therefore the 80/20 system shall be applicable.

1.3 Preference points for this bid shall be awarded for:

- (a) Price; and
- (b) Specific contract participation goals, as specified in the attached forms.

1.3.1 The points for this bid are allocated as follows:

1.3.1.1 PRICE 80

1.3.1.2 SPECIFIC CONTRACT PARTICIPATION GOALS

- (a) Historically Disadvantaged Individuals:**
- (i) who had no franchise in national elections before the 1983 and 1993 Constitutions 8
- (ii) Woman ownership 1
- (iii) Disability 1
- (b) Other specific goals (goals of the RDP- plus local manufacture)**
- (i) Supplier within Western Cape 10

Total points for Price, HDIs and other RDP-goals must not exceed 100

Separate Preference Points Claim Forms will be used for the promotion of the specific goals for which points have been allocated in paragraph 1.3.1.2 (b) above.

1.4 Failure on the part of a bidder to fill in and/or to sign this form may be interpreted to mean that preference points are not claimed.

1.5 The purchaser reserves the right to require of a bidder, either before a bid is adjudicated or at any time subsequently, to substantiate any claim in regard to preferences, in any manner required by the purchaser.

2. GENERAL DEFINITIONS

- 2.1 “**Acceptable bid**” means any bid which, in all respects, complies with the specifications and conditions of bid as set out in the bid document.
- 2.2 “**Bid**” means a written offer in a prescribed or stipulated form in response to an invitation by an organ of state for the provision of goods, works or services.
- 2.3 “**Comparative price**” means the price after the factors of a non-firm price and all unconditional discounts that can be utilised have been taken into consideration.
- 2.4 “**Consortium or joint venture**” means an association of persons for the purpose of combining their expertise, property, capital, efforts, skills and knowledge in an activity for the execution of a contract.
- 2.5 “**Contract**” means the agreement that results from the acceptance of a bid by an organ of state.
- 2.6 “**Specific contract participation goals**” means the goals as stipulated in the Preferential Procurement Regulations 2001.
- 2.6.1 In addition to above-mentioned goals, the Regulations [12.(1)] also make provision for organs of state to give particular consideration to procuring locally manufactured products.
- 2.7 “**Control**” means the possession and exercise of legal authority and power to manage the assets, goodwill and daily operations of a business and the active and continuous exercise of appropriate managerial authority and power in determining the policies and directing the operations of the business.
- 2.8 “**Disability**” means, in respect of a person, a permanent impairment of a physical, intellectual, or sensory function, which results in restricted, or lack of, ability to perform an activity in the manner, or within the range, considered normal for a human being.
- 2.9 “**Equity Ownership**” means the percentage ownership and control, exercised by individuals within an enterprise.
- 2.10 “**Historically Disadvantaged Individual (HDI)**” means a South African citizen
- (1) who, due to the apartheid policy that had been in place, had no franchise in national elections prior to the introduction of the Constitution of the Republic of South Africa, 1983 (Act No 110 of 1983) or the Constitution of the Republic of South Africa, 1993, (Act No 200 of 1993) (“the interim Constitution”); and/or
 - (2) who is a female; and/or
 - (3) who has a disability:

provided that a person who obtained South African citizenship on or after the coming to effect of the Interim Constitution, is deemed not to be a HDI;
- 2.11 “**Management**” means an activity inclusive of control and performed on a daily basis, by any person who is a principal executive officer of the company, by whatever name that person may be designated, and whether or not that person is a director.
- 2.12 “**Owned**” means having all the customary elements of ownership, including the right of decision-making and sharing all the risks and profits commensurate with the degree of ownership interests as demonstrated by an examination of the substance, rather than the form of ownership arrangements.

- 2.13 “**Person**” includes reference to a juristic person.
- 2.14 “**Rand value**” means the total estimated value of a contract in Rand denomination that is calculated at the time of bid invitations and includes all applicable taxes and excise duties.
- 2.15 “**Small, Medium and Micro Enterprises (SMMEs)**” bears the same meaning assigned to this expression in the National Small Business Act, 1996 (No 102 of 1996).
- 2.16 “**Sub-contracting**” means the primary contractor’s assigning or leasing or making out work to, or employing another person to support such primary contractor in the execution of part of a project in terms of the contract.
- 2.17 “**Trust**” means the arrangement through which the property of one person is made over or bequeathed to a trustee to administer such property for the benefit of another person.
- 2.18 “**Trustee**” means any person, including the founder of a trust, to whom property is bequeathed in order for such property to be administered for the benefit of another person.

3. ESTABLISHMENT OF HDI EQUITY OWNERSHIP IN AN ENTERPRISE

- 3.1 Equity ownership shall be equated to the percentage of an enterprise which is owned by individuals classified as HDIs, or in the case of a company, the percentage shares that are owned by individuals classified as HDIs, who are actively involved in the management and daily business operations of the enterprise and exercise control over the enterprise, commensurate with their degree of ownership.
- 3.2 Where individuals are not actively involved in the management and daily business operations and do not exercise control over the enterprise commensurate with their degree of ownership, equity ownership may not be claimed.

4. ADJUDICATION USING A POINT SYSTEM

- 4.1 The bidder obtaining the highest number of points will be awarded the contract.
- 4.2 Preference points shall be calculated after prices have been brought to a comparative basis.
- 4.3 Points scored will be rounded off to 2 decimal places.
- 4.4 In the event of equal points scored, the bid will be awarded to the bidder scoring the highest number of points for specified goals.

5. POINTS AWARDED FOR PRICE

5.1 THE 80/20 OR 90/10 PREFERENCE POINT SYSTEMS

A maximum of 80 or 90 points is allocated for price on the following basis:

$$\begin{array}{ccc}
 \mathbf{80/20} & \mathbf{or} & \mathbf{90/10} \\
 \\
 P_s = 80 \left(1 - \frac{P_t - P_{\min}}{P_{\min}} \right) & \text{or} & P_s = 90 \left(1 - \frac{P_t - P_{\min}}{P_{\min}} \right)
 \end{array}$$

Where

- P_s = Points scored for price of bid under consideration
- P_t = Rand value of bid under consideration
- P_{min} = Rand value of lowest acceptable bid

6. Points awarded for historically disadvantaged individuals

6.1 In terms of Regulation 13 (2) preference points for HDI's are calculated on their percentage shareholding in a business, provided that they are actively involved in and exercise control over the enterprise. The following formula is prescribed in Regulation 13 (5) (c):

$$NEP = NOP \times \frac{EP}{100}$$

Where

NEP = Points awarded for equity ownership by an HDI

NOP = The maximum number of points awarded for equity ownership by an HDI in that specific category

EP = The percentage of equity ownership by an HDI within the enterprise or business, determined in accordance with the definition of HDI's.

6.2 Equity claims for a trust will only be allowed in respect of those persons who are both trustees and beneficiaries and who are actively involved in the management of the trust.

6.3 Documentation to substantiate the validity of the credentials of the trustees contemplated above must be submitted.

6.2 Listed companies and tertiary institutions do not qualify for HDI preference points.

6.5 A consortium or joint venture may, based on the percentage of the contract value managed or executed by their HDI-members, be entitled to preference points in respect of an HDI.

6.6 A person awarded a contract as a result of preference for contracting with, or providing equity ownership to an HDI, may not subcontract more than 25% of the value of the contract to a person who is not an HDI or does not qualify for the same number or more preference for equity ownership.

7. BID DECLARATION

7.1 Bidders who claim points in respect of equity ownership must complete the Bid Declaration at the end of this form.

8. EQUITY OWNERSHIP CLAIMED IN TERMS OF PARAGRAPH 2.10 ABOVE. POINTS TO BE CALCULATED FROM INFORMATION FURNISHED IN PARAGRAPH 9.8.

| Ownership | Percentage owned | Points claimed |
|--|------------------|----------------|
| 8.1 Equity ownership by persons who had no franchise in the national elections | % x 8 | |
| 8.2 Women ownership | % x 1 | |
| 8.3 Disability | % x 1 | |

9 DECLARATION WITH REGARD TO EQUITY

9.1 Name of firm :

9.2 VAT registration number :

9.3 Company registration number :

9.4 TYPE OF FIRM

- Partnership
- One person business/sole trader
- Close corporation
- Company
- (Pty) Limited
- [TICK APPLICABLE BOX]

9.5 DESCRIBE PRINCIPAL BUSINESS ACTIVITIES

.....

.....

.....

9.6 COMPANY CLASSIFICATION

- Manufacturer
- Supplier
- Professional service provider
- Other service providers, e.g. transporter, etc.
- [TICK APPLICABLE BOX]

9.7 MUNICIPAL INFORMATION

Municipality where business is situated:

Registered Account No:

Stand No:

Please attach a copy of your latest municipal account

9.8 TOTAL NUMBER OF YEARS THE FIRM HAS BEEN IN BUSINESS

9.9 List all Shareholders by Name, Position, Identity Number, Citizenship, HDI status and ownership, as relevant. Information to be used to calculate the points claimed in paragraph 8.

| Name | Date/Position occupied in Enterprise | ID Number | Date RSA Citizenship obtained | * HDI Status | | | % of business / enterprise owned |
|------|--------------------------------------|-----------|-------------------------------|---------------------------------|-------|----------|----------------------------------|
| | | | | No franchise prior to elections | Women | Disabled | |
| | | | | | | | |
| | | | | | | | |
| | | | | | | | |
| | | | | | | | |
| | | | | | | | |
| | | | | | | | |

*Indicate YES or NO

9.10.1 Consortium / Joint Venture

9.10.2 In the event that preference points are claimed for HDI members by consortia / joint ventures, the following information must be furnished in order to be entitled to the points claimed in respect of the HDI member:

| Name of HDI member (to be consistent with paragraph 9.9) | Percentage (%) of the contract value managed or executed by the HDI member |
|--|--|
| | |
| | |
| | |
| | |
| | |
| | |
| | |
| | |

9.10.2 I/we, the undersigned, who warrants that he/she is duly authorised to do so on behalf of the firm certify that points claimed, based on the equity ownership, indicated in paragraph 8 of the foregoing certificate, qualifies the firm for the preference(s) shown and I / we acknowledge that:

- (i) The information furnished is true and correct.
- (ii) The Equity ownership claimed is in accordance with the General Conditions as indicated in paragraph 1 of this form.
- (iii) In the event of a contract being awarded as a result of points claimed as shown in paragraph 8, the contractor may be required to furnish documentary proof to the satisfaction of the purchaser that the claims are correct.
- (iv) If the claims are found to be incorrect, the purchaser may, in addition to any other remedy it may have -
 - (a) recover costs, losses or damages it has incurred or suffered as a result of that person's conduct; and
 - (b) cancel the contract and claim any damages which it has suffered as a result of having to make less favourable arrangements due to such cancellation;

WITNESSES:

- 1.
- 2.

SIGNATURE (S) OF BIDDER (S)

DATE:

ADDRESS:

.....

.....

**PREFERENCE POINTS CLAIM FORM IN TERMS OF THE PREFERENTIAL PROCUREMENT REGULATIONS 2001
PROMOTION OF ENTERPRISES LOCATED IN THE WESTERN PROVINCE**

NB: BEFORE COMPLETING THIS FORM, BIDDERS MUST STUDY THE GENERAL CONDITIONS, DEFINITIONS AND DIRECTIVES SPECIFIED IN CLAIM FORM MBD 6.1 AND THE PREFERENTIAL PROCUREMENT REGULATIONS, 2001.

1. Regulation 17(3) (e) of the Preferential Procurement Regulations makes provision for the promotion of enterprises located in a specific province for work to be done or services to be rendered in that province.
2. The promotion of this goal can be achieved by acquiring goods and services from enterprises located within the Western Province. This includes an enterprise whose head office may be situated in another province, but has established a fully-fledged branch within the Province. Enterprises located outside the borders of the Province and who only appoint agents and/or commission warehouses in the Province are expressly excluded from claiming points for this goal.

SPECIFIC GOAL

POINTS ALLOCATED

The stimulation of the Provincial economy by procuring locally **10**

3. Preference points may only be claimed by enterprises located within the borders of the Western Province. (See paragraph 2 above).

4. BID DECLARATION

Bidders who wish to claim points in respect of this specific goal must complete the declaration part of this form.

5. POINTS CLAIMED

Bidder to indicate whether the point(s) allocated for enterprises situated within the borders of the Western Province is/are claimed. **Yes / No**

6. DECLARATION WITH REGARD TO LOCALITY

State full particulars of locality of enterprise as well as that of Head Office:

Address of local enterprise:

Physical: Postal:

.....

.....

Telephone: Fax:

Municipal Account No: Stand No:

Address of Head Office:

Physical.....Postal:

.....

.....

.....

Telephone:Fax:

I/we, the undersigned, who warrants that he/she is duly authorised to do so on behalf of the enterprise certify that the enterprise is entitled to the points allocated in paragraph 2 of this form and I / we acknowledge that:

- (i) The information furnished is true and correct.
- (ii) In the event of a contract being awarded as a result of points claimed, the contractor may be required to furnish documentary proof to the satisfaction of the purchaser that the claim is correct.
- (iii) If the claim is found to be incorrect, the purchaser may, in addition to any other remedy it may have-
 - (a) recover all costs, losses or damages it has incurred or suffered as a result of wrong information furnished; and
 - (b) cancel the contract and claim any damages which it has suffered as a result of having to make less favourable arrangements due to such cancellation;

WITNESSES:

1.

| |
|---|
| SIGNATURE (S) OF BIDDER (S) |
|---|

2.

DATE:

DECLARATION OF BIDDER'S PAST SUPPLY CHAIN MANAGEMENT PRACTICES

- 1 This Municipal Bidding Document must form part of all bids invited.
- 2 It serves as a declaration to be used by municipalities and municipal entities in ensuring that when goods and services are being procured, all reasonable steps are taken to combat the abuse of the supply chain management system.
- 3 The bid of any bidder may be rejected if that bidder, or any of its directors have:
 - a. abused the municipality's / municipal entity's supply chain management system or committed any improper conduct in relation to such system;
 - b. been convicted for fraud or corruption during the past five years;
 - c. willfully neglected, reneged on or failed to comply with any government, municipal or other public sector contract during the past five years; or
 - d. been listed in the Register for Tender Defaulters in terms of section 29 of the Prevention and Combating of Corrupt Activities Act (No 12 of 2004).
- 4 **In order to give effect to the above, the following questionnaire must be completed and submitted with the bid.**

| | | | |
|-------|---|---------------------------------|--------------------------------|
| 4.1 | Is the bidder or any of its directors listed on the National Treasury's database as a company or person prohibited from doing business with the public sector? (Companies or persons who are listed on this database were informed in writing of this restriction by the National Treasury after the <i>audi alteram partem</i> rule was applied). | Yes <input type="checkbox"/> | No <input type="checkbox"/> |
| 4.1.1 | If so, furnish particulars: | | |
| 4.2 | Is the bidder or any of its directors listed on the Register for Tender Defaulters in terms of section 29 of the Prevention and Combating of Corrupt Activities Act (No 12 of 2004)? (To access this Register enter the National Treasury's website, www.treasury.gov.za, click on the icon "Register for Tender Defaulters" or submit your written request for a hard copy of the Register to facsimile number (012) 326-5445). | Yes <input type="checkbox"/> | No <input type="checkbox"/> |
| 4.2.1 | If so, furnish particulars: | | |
| 4.3 | Was the bidder or any of its directors convicted by a court of law (including a court of law outside the Republic of South Africa) for fraud or corruption during the past five years? | Yes <input type="checkbox"/> | No <input type="checkbox"/> |

| | | | |
|-------|--|---------------------------------|--------------------------------|
| 4.3.1 | If so, furnish particulars: | | |
| | | | |
| 4.4 | Does the bidder or any of its directors owe any municipal rates and taxes or municipal charges to the municipality / municipal entity, or to any other municipality / municipal entity, that is in arrears for more than three months? | Yes <input type="checkbox"/> | No <input type="checkbox"/> |
| 4.4.1 | If so, furnish particulars: | | |
| 4.5 | Was any contract between the bidder and the municipality / municipal entity or any other organ of state terminated during the past five years on account of failure to perform on or comply with the contract? | Yes <input type="checkbox"/> | No <input type="checkbox"/> |
| 4.7.1 | If so, furnish particulars: | | |

CERTIFICATION

I, THE UNDERSIGNED (FULL NAME)

CERTIFY THAT THE INFORMATION FURNISHED ON THIS DECLARATION FORM IS TRUE AND CORRECT.

I ACCEPT THAT, IN ADDITION TO CANCELLATION OF A CONTRACT, ACTION MAY BE TAKEN AGAINST ME SHOULD THIS DECLARATION PROVE TO BE FALSE.

.....

Signature

.....

Date

.....

Position

.....

Name of Bidder

CERTIFICATE OF INDEPENDENT BID DETERMINATION

- 1 This Municipal Bidding Document (MBD) must form part of all bids¹ invited.
- 2 Section 4 (1) (b) (iii) of the Competition Act No. 89 of 1998, as amended, prohibits an agreement between, or concerted practice by, firms, or a decision by an association of firms, if it is between parties in a horizontal relationship and if it involves collusive bidding (or bid rigging)². Collusive bidding is a *pe se* prohibition meaning that it cannot be justified under any grounds.
- 3 Municipal Supply Regulation 38 (1) prescribes that a supply chain management policy must provide measures for the combating of abuse of the supply chain management system, and must enable the accounting officer, among others, to:
 - a. take all reasonable steps to prevent such abuse;
 - b. reject the bid of any bidder if that bidder or any of its directors has abused the supply chain management system of the municipality or municipal entity or has committed any improper conduct in relation to such system; and
 - c. cancel a contract awarded to a person if the person committed any corrupt or fraudulent act during the bidding process or the execution of the contract.
- 4 This MBD serves as a certificate of declaration that would be used by institutions to ensure that, when bids are considered, reasonable steps are taken to prevent any form of bid-rigging.
- 5 In order to give effect to the above, the attached Certificate of Bid Determination (MBD 9) must be completed and submitted with the bid:

¹ Includes price quotations, advertised competitive bids, limited bids and proposals.

² Bid rigging (or collusive bidding) occurs when businesses, that would otherwise be expected to compete, secretly conspire to raise prices or lower the quality of goods and / or services for purchasers who wish to acquire goods and / or services through a bidding process. Bid rigging is, therefore, an agreement between competitors not to compete.

CERTIFICATE OF INDEPENDENT BID DETERMINATION

I, the undersigned, in submitting the accompanying bid:

BID NO: 08/2/9/10: SUPPLY AND DELIVERY OF 12 X 6M³ SKIP BINS

in response to the invitation for the bid made by:

WITZENBERG MUNICIPALITY

do hereby make the following statements that I certify to be true and complete in every respect:

I certify, on behalf of: _____ that:
(Name of Bidder)

1. I have read and I understand the contents of this Certificate;
2. I understand that the accompanying bid will be disqualified if this Certificate is found not to be true and complete in every respect;
3. I am authorized by the bidder to sign this Certificate, and to submit the accompanying bid, on behalf of the bidder;
4. Each person whose signature appears on the accompanying bid has been authorized by the bidder to determine the terms of, and to sign, the bid, on behalf of the bidder;
5. For the purposes of this Certificate and the accompanying bid, I understand that the word "competitor" shall include any individual or organization, other than the bidder, whether or not affiliated with the bidder, who:
 - (a) has been requested to submit a bid in response to this bid invitation;
 - (b) could potentially submit a bid in response to this bid invitation, based on their qualifications, abilities or experience; and
 - (c) provides the same goods and services as the bidder and/or is in the same line of business as the bidder, who:
6. The bidder has arrived at the accompanying bid independently from, and without consultation, communication, agreement or arrangement with any competitor. However communication between partners in a joint venture or consortium³ will not be construed as collusive bidding.

³ Joint venture or Consortium means an association of persons for the purpose of combining their expertise, property, capital, efforts, skill and knowledge in an activity for the execution of a contract.

7. In particular, without limiting the generality of paragraphs 6 above, there has been no consultation, communication, agreement or arrangement with any competitor regarding:
- (a) prices;
 - (b) geographical area where product or service will be rendered (market allocation)
 - (c) methods, factors or formulas used to calculate prices;
 - (d) the intention or decision to submit or not to submit, a bid;
 - (e) the submission of a bid which does not meet the specifications and conditions of the bid; or
 - (f) bidding with the intention not to win the bid.
8. In addition, there have been no consultations, communications, agreements or arrangements with any competitor regarding the quality, quantity, specifications and conditions or delivery particulars of the products or services to which this bid invitation relates.
9. The terms of the accompanying bid have not been, and will not be, disclosed by the bidder, directly or indirectly, to any competitor, prior to the date and time of the official bid opening or of the awarding of the contract.
10. I am aware that, in addition and without prejudice to any other remedy provided to combat any restrictive practices related to bids and contracts, bids that are suspicious will be reported to the Competition Commission for investigation and possible imposition of administrative penalties in terms of section 59 of the Competition Act No. 89 of 1998 and or may be reported to the National Prosecuting Authority (NPA) for criminal investigation and or may be restricted from conducting business with the public sector for a period not exceeding ten (10) years in terms of the Prevention and Combating of Corrupt Activities Act No. 12 of 2004 or any other applicable legislation.

.....
Signature

.....
Date

.....
Position

.....
Name of Bidder



BID NO 08/2/9/10: SUPPLY AND DELIVERY OF 12 X 6M³ SKIP BINS

Authorization to deduct outstanding amounts

To: Municipal Manager, Witzenberg Municipality

From: _____
(Name of Bidder or Consortium)

AUTHORISATION FOR THE DEDUCTION OF OUTSTANDING AMOUNTS OWED TO COUNCIL

I, THE UNDERSIGNED,

(FULL NAME IN BLOCK LETTERS)

Hereby authorise the Witzenberg Municipality to deduct the full amount outstanding by the business organization / Director, shareholder, partner, etc from any payment due to us / me.

.....
Signature

THUS DONE AND SIGNED for and on behalf on the Bidder / Contractor

at on the day of 20.....
(Place) (Date) (Month) (Year)
in the presence of the subscribing witnesses.

AS WITNESSES:

1..... Name in Block Letters:
(SIGNATURE)

2..... Name in Block Letters:
(SIGNATURE)

To: Municipal Manager, Witzenberg Municipality

CERTIFICATE FOR MUNICIPAL SERVICES AND PAYMENTS TO SERVICE PROVIDER

BID NO 08/2/9/10: SUPPLY AND DELIVERY OF 12 X 6M³ SKIP BINS

NAME OF THE BIDDER:

FURTHER DETAILS OF THE BIDDER/S; Proprietor / Director/s / Partners, etc:

| Physical business address of Bidder | Municipal Account numbers |
|-------------------------------------|---------------------------|
| | |
| | |
| | |
| | |

If there is not enough space for all the names, please attach the additional details to the Bid Document

| Name of Director/Member/Partner | Identity number | Physical residential address of Director/Member/Partner | Municipal Account numbers |
|---------------------------------|-----------------|---|---------------------------|
| | | | |
| | | | |
| | | | |
| | | | |
| | | | |

I, _____, the undersigned,
 (full name in block letters)

certify that the information furnished on this declaration form is correct and that I/we have no undisputed commitments for municipal services towards a municipality or other service provider in respect of which payment is overdue for more than 30 days. Bidder must attach copy of municipal account.

 Signature

THUS DONE AND SIGNED for and on behalf on the Bidder / Contractor

at on the day of 20.....
 (PLACE) (DATE) (MONTH) (YEAR)

Please Note:
 Even if the requested information is not applicable to the Bidder, the table above should be endorsed and **THIS DECLARATION MUST STILL BE SIGNED.**



CHECK LIST FOR COMPLETENESS OF BID DOCUMENT

The bidder must ensure that the following checklist is completed, that the necessary documentation is attached to this bid document and that all declarations are signed:

**Mark with "X" where applicable*

| Items to be checked | Yes | No | Comments |
|--|-----|----|----------|
| 1. Completed page containing the details of bidder | | | |
| 2. Valid and original tax clearance certificate attached to bid document (MBD 2). Bidders who are registered on the municipality's accredited supplier database and attached an original valid tax clearance certificate to their application form does not need to submit an original tax clearance certificate with their bid document. However, the onus is on the bidder to confirm with the Supply Chain Unit whether or not his/ her tax clearance certificate that was submitted with the supplier application form will be valid at the time of bid closing. | | | |
| 3. Adhered to the pricing instructions (MBD 3.1) | | | |
| 4. Completed and signed declaration of interest (MBD 4) | | | |
| 5. Preference points claimed and signed declarations (MBD 6.1 to 6.12 where applicable) | | | |
| 6. Signed declaration of bidder's past supply chain management practices (MBD 8) | | | |
| 7. Prohibition of Restrictive Practices (MBD 9) be completed and signed | | | |
| 8. Comply with full specification | | | |
| 9. Bidder must initial every page of this bid document | | | |
| 10. Latest municipal account of the bidder and its directors must be attached a. If the bidder is not responsible for the payment of municipal rates and/ services, details in support of this must be attached to this bid document e.g. letter from landlord | | | |

CERTIFICATION

I, THE UNDERSIGNED (FULL NAME)

CERTIFY THAT THE INFORMATION FURNISHED ON THIS CHECK LIST IS TRUE AND CORRECT.

.....

Signature

.....

Position

.....

Date

.....

Name